

DRILL 1"(25mm) HOLE  
AT CENTER OF  
DOOR EDGE

FOLD ON DOOR EDGE  
FOLD ON DOOR EDGE

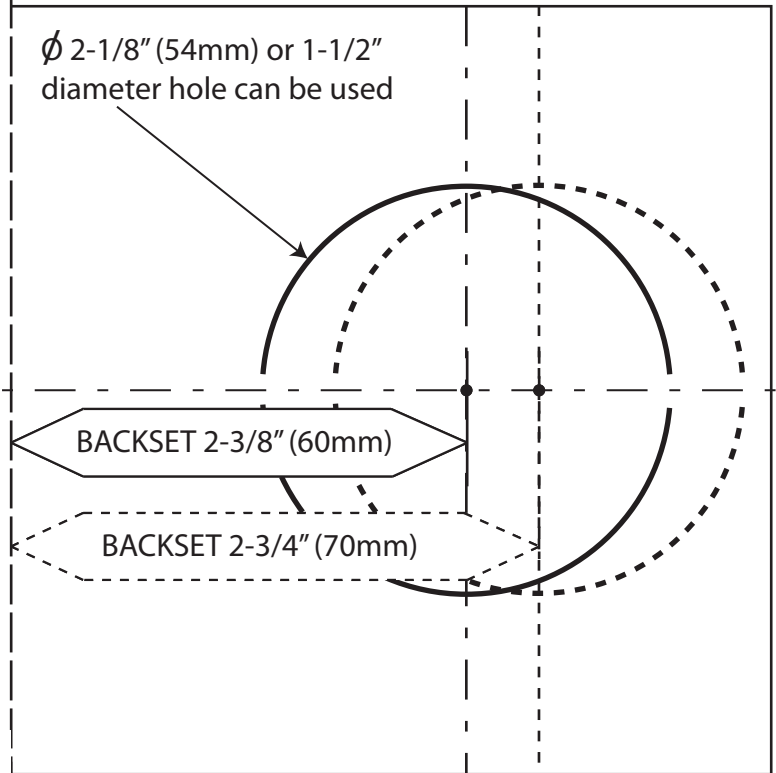
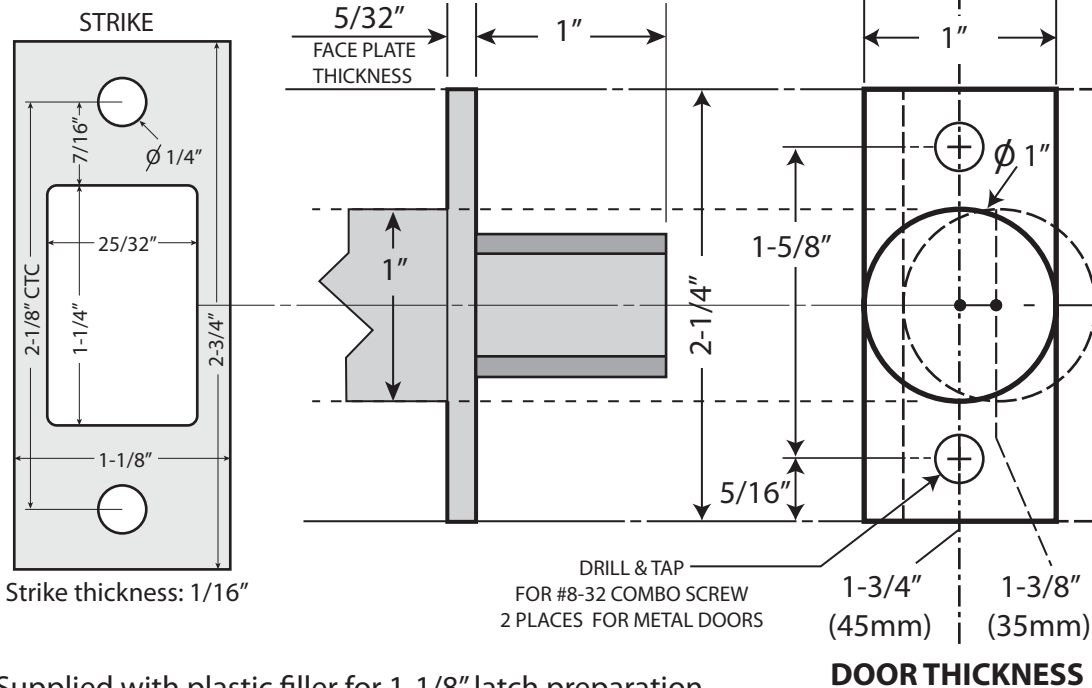

Supplied with plastic filler for 1-1/8" latch preparation

### 1. MARK DOOR

- Fold and apply to high edge of door bevel and mark center of door edge as indicated on template at the desired height from the floor.
- Mark center hole on door face through guide on template for 2-3/8" (60mm) or 2-3/4" (70mm) backset.

### 2. DRILL HOLES

- Drill halfway thru door face (inside face). Standard 2-1/8" diameter hole or 1-1/2" diameter hole can be used
  - Drill 1"(25mm) hole in center of door edge thru 2-1/8"(54mm) hole for latch.
- CAUTION: Check center of latch hole for alignment with strike center on jamb to ensure free movement of latch bolt.



6605 Flotilla St.  
City of Commerce  
CA 90040 USA  
Tel: (323) 888-6601  
FAX: (323) 888-6699  
Website: cal-royal.com  
Email: sales@cal-royal.com

ITEM NO.	DESCRIPTION	ANSI	SCALE	UNIT	VERSION
<b>ID58</b>	<b>ONE SIDED DEADBOLT</b>	Grade 3	1 : 1	inches (mm)	ver. 1.0 rev. 01/12
			PAGE 1 OF 1		<b>BY: bteves</b>